

Powder Spray for Slabs

This system marks characters on the surface of hot slabs, defined by a bright, white line ("handwritten" type) obtained spraying a special metal powder handled by an automatic ZY table. The system assures high marking speed and excellent reliability; markings are very well readable, even in presence of irregular surfaces, also from long distance.

Main Marking Features

- Hot application up to 1200 °C
- Marking position: on the front or side surface
- One or more lines, min. character height 40 mm
- Symbols: letters, numbers, special characters (logos)
- Standard or OCR fonts



System configuration

- Machine structure (with one or more marking heads) available in various configuration:
- Bridge with single or multiple mobile carriages, to be placed across the CC exit line (front marking) or aside the line (side marking)
- Ground basement with single or multiple mobile carriages, to be placed at the end of CC exit line (front marking) or aside the line (side marking)
- Integrated cooling system
- Pneumatic cabinet
- Powder feeding group with air drier

- Thermal protection
- Power and Control cabinet
- Control desk with HMI

Functional features

Automatic detection of product dimension and position (centering device)
 Many parameters can be adjusted / selected by the operator via Control Unit, f.i.:

- Characters dimension (width, compression, height)
- Host connection (Ethernet, Profibus or other common industrial fieldbus)

Optional function

- High pressure water descaler
- Mechanical descaler
- Using OCR fonts, markings can be automatically read by our AURS system (combined marking / reading function to achieve automatic tracking of slabs)

Powder features

Type: metal base powder
 Colour: white
 Toxicity: not toxic
 Consumption: from 0.5 to 2 g/character according to size

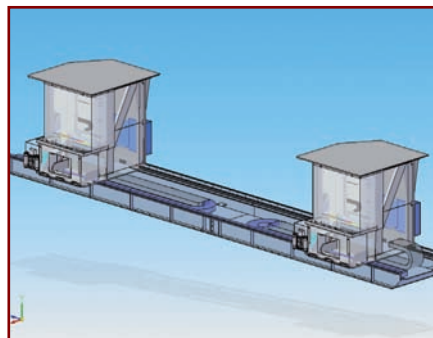
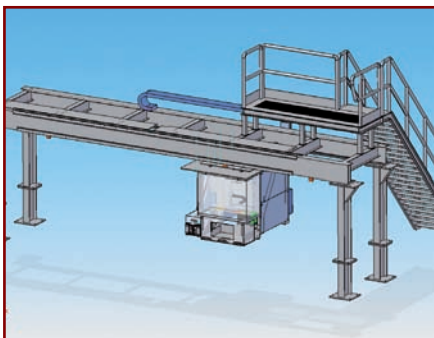

Certif. n° 1235/98



Certif. n° EMS-1724/S

